

**United**  
United California Corporation  
United Drill Bushing Corporation  
United Screw Products Company

12200 Woodruff Ave. - Downey, CA 90241-5608  
P.O. Box 4250 - Downey, CA 90241-1250  
Ph: 562-803-1521 800-421-3466 in CA - 800-486-3466  
Fax: 562-803-6898 - 800-486-3465  
Email: [united@ucc-udb.com](mailto:united@ucc-udb.com) Web: [www.ucc-udb.com](http://www.ucc-udb.com)

Refer  
to  
Section K  
In our  
**UNITED**  
CATALOG

Refer  
to  
Section K  
On our  
Website  
[www.ucc-udb.com](http://www.ucc-udb.com)



## HOIST RING LIFTING DEVICES — SAFETY INFORMATION

United products are intended for use only by trained, qualified and experienced workmen. Misuse of any UDB product or lack of supervision and inspection can lead to serious accidents including death. United always stresses that safety is of utmost importance!

Prior to any use of United products evaluation of the product application, safety precautions, safe working load, and control of all field conditions are mandatory. Eliminate applications that exceed the safe working load or any other product misuse. United advises that all safety factors shown are approximate. Do not exceed safe working loads under any circumstances.

If you have any questions about the proper use or installation of any United product, please contact our office directly at **UNITED 12200 Woodruff Avenue, Downey, CA 90241 Phone: 1-800-486-3466 Email: [united@ucc-udb.com](mailto:united@ucc-udb.com)**

### Safety Notes:

United ensures that all materials used on all our products meet or exceed the safety requirements for lifting. The safe working loads listed are based upon a new or "as new" products. A safe working load is considered to be maximum allowable load that may be applied to an item at any time.

### Inspection & Maintenance:

In order to ensure the safest lifting, all United products must be used and maintained in the proper manner provided. Hoist rings are subject to wear, corrosion, deformation, overloading, and other limiting factors which will affect the safe working load. Prior to use of any United product, the product should be regularly inspected to determine if it may be used or whether it should be removed from service. It is your responsibility to inspect all lifting units for signs of wear and to discard any parts showing visible signs of wear. Every user should establish a safety inspection program for routine visual inspection of all products to determine whether signs of wear (e.g. cracks, corrosion, deformation) are present. The product inspection schedule should be established based upon factors such as frequency of use, period of use and environment.

**In addition to the regular safety inspection, the following *TEN SAFETY DIRECTIVES ARE MANDATORY!***

1. Prior to use, always inspect hoist rings for possible wear or damage. Do not use hoist rings that show any sign of wear or damage.
2. Do not use hoist rings if the bail is bent or elongated.
3. Prior to use, threads must be clean, undamaged, and must fit properly.
4. Always install hoist rings using the listed torque values. Periodically check torque and prevent loosening during extended service.
5. Bent bolts should be discarded. All bent bolts must be replaced. Failing to do so may lead to serious injuries or death.
6. Never use washers or any spacers between bushing and mounting surface.
7. Always make sure the hoist ring pivots and rotates in all directions freely before using.
8. Never use hoist rings near corrosive materials.
9. If hoist rings are exposed to extreme temperatures, please contact our engineering department for consultation and directions.
10. Never exceed any safe working loads.

If there are questions regarding the replacement or repair of worn United products, please contact our engineering department.

**We repair and refurbish hoist rings. Advise us of your requirements.**

**Phone: 1-800-486-3466 Fax: 562-803-6898 Email: [united@ucc-udb.com](mailto:united@ucc-udb.com)**  
**Visit our *United* Website for details and complete Catalog at [www.ucc-udb.com](http://www.ucc-udb.com)**



**United California Corporation**  
**United Drill Bushing Corporation**  
**United Screw Products Company**

12200 Woodruff Ave. - Downey, CA 90241-5608  
 P.O. Box 4250 - Downey, CA 90241-1250  
 Ph: 562-803-1521 800-421-3466 in CA - 800-486-3466  
 Fax: 562-803-6898 - 800-486-3465  
 Email: united@ucc-udb.com Web: www.ucc-udb.com



Refer  
to  
Section K  
In our  
**UNITED**  
CATALOG



Refer  
to  
Section K  
On our  
Website  
[www.ucc-udb.com](http://www.ucc-udb.com)



## SIDE PULL HOIST RINGS — SAFETY PRECAUTIONS

**WARNING: PLEASE READ THE FOLLOWING FOR HOIST RING PROPER INSTALLATION PRIOR TO USE.**

Regular inspection for wear and strict adherence to instructions is essential to prevent misuse failure.

**CAUTION: Rated capacity is for STRAIGHT LIFTS. Angle lifts should be avoided. Load limits are reduced by as much as 75% on angle lifts!**

Despite the 5:1 safety factor, **NEVER EXCEED THE RATED LOAD CAPACITY.** This safety margin is needed in case of misuse which could drastically lower load capacity.

Tighten mounting screws to torques recommended. Periodically check torque because screws could loosen in extended service.

Tensile strength of parent material should be above 80,000 PSI to achieve full load rating. For weaker material, consider through-hole mounting with a nut and washer on the other side.

**DO NOT APPLY SHOCK LOADS.** Always lift gradually. Repeat magnaflux testing if shock loading ever occurs.

**CAUTION: Rated capacity is for STRAIGHT LIFTS. Angle lifts should be avoided. Load limits are reduced by as much as 75% on angle lifts!**

**Be safe and check to see that hoist ring pivots and rotates in all directions freely.**

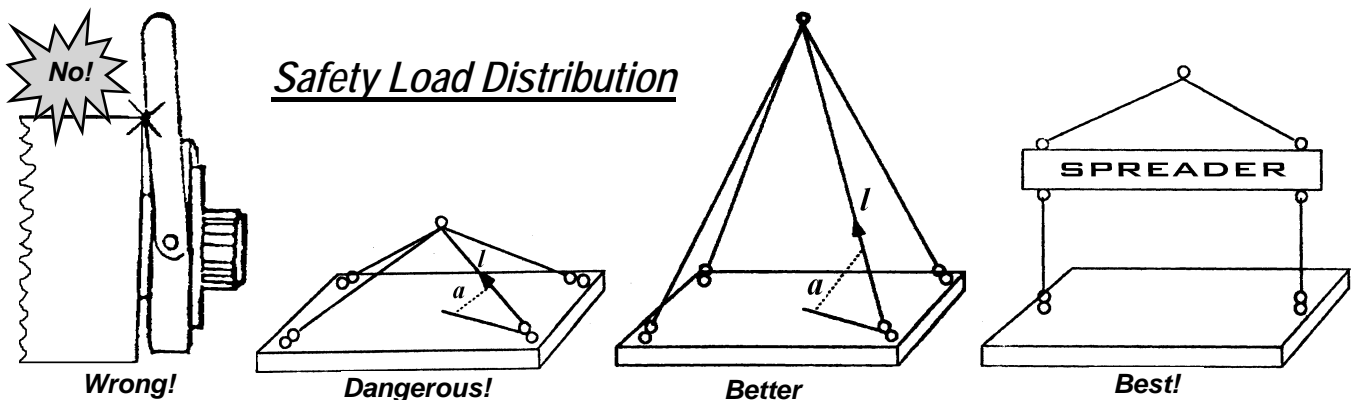

We repair and refurbish hoist rings. Advise us of your requirements.

Phone: 1-800-486-3466 Fax: 562-803-6898 Email: united@ucc-udb.com  
 Visit our *United* Website for details and complete Catalog at [www.ucc-udb.com](http://www.ucc-udb.com)



**United California Corporation**  
**United Drill Bushing Corporation**  
**United Screw Products Company**

12200 Woodruff Ave. - Downey, CA 90241-5608  
 P.O. Box 4250 - Downey, CA 90241-1250  
 Ph: 562-803-1521 800-421-3466 in CA - 800-486-3466  
 Fax: 562-803-6898 - 800-486-3465  
 Email: united@ucc-udb.com Web: www.ucc-udb.com

**FORGED SWIVEL HOIST RINGS — SAFETY PRECAUTIONS**

**WARNING: BEFORE USING ANY UNITED HOIST RINGS, PLEASE READ THE FOLLOWING FOR PROPER INSTALLATION AND USAGE.**

Regular inspection for wear and strict adherence to use instructions are necessary to prevent misuse failure and accidents.

Despite the 5:1 safety factor, **NEVER EXCEED THE RATED LOAD CAPACITY.** This safety margin is needed in case of misuse, which could drastically lower load capacity.

Tensile strength of parent material should be above 80,000 PSI to achieve full load rating. For weaker material, consider through-hole mounting with a nut and washer on the other side.

**Tighten mounting screws** to torque recommended. Periodically check torque because screws could loosen in extended service.

**DO NOT APPLY SHOCK LOADS.** Always lift gradually. Repeat magnaflux testing if shock loading ever occurs.

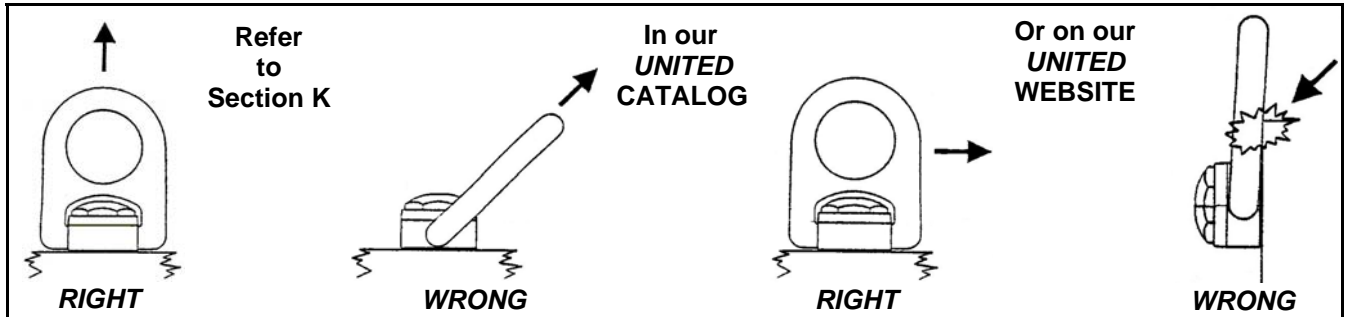

**Important:** The load on each hoist ring may not be the total weight divided by the number of hoist rings. The resultant forces can be significantly greater at shallow lift angles and with unevenly distributed loads. See examples A and B below.

**FORMULA:**  $l = \frac{w}{n \sin a}$

$l$  = LIFT STRENGTH OF EACH HOIST RING  
 $w$  = WEIGHT TOTAL  
 $n$  = NUMBER OF HOIST RINGS  
 $a$  = ANGLE OF LIFT

EXAMPLE B:  $w = 2000$  LBS.,  $n = 4$ ,  $a = 60^\circ$

$l = \frac{2000}{4 \sin 60} = 577$  LBS. EACH HOIST

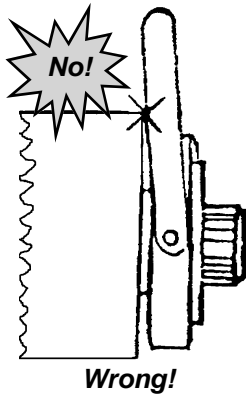

EXAMPLE A:  $w = 2000$  LBS.,  $n = 4$ ,  $a = 20^\circ$

$l = \frac{2000}{4 \sin 20} = 1462$  LBS. EACH HOIST

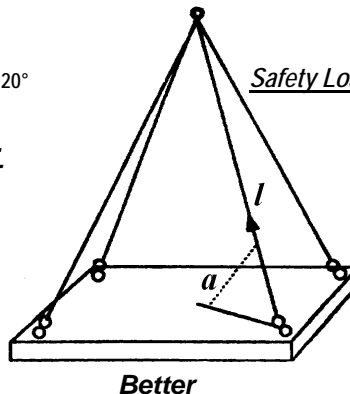
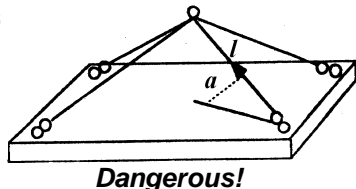

*Safety Load Distribution*

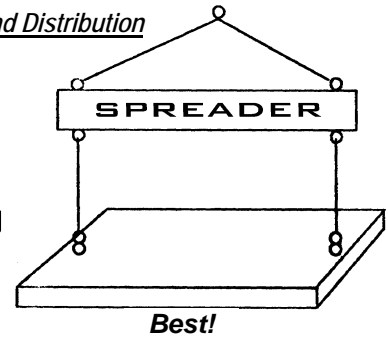

We repair and refurbish hoist rings. Advise us of your requirements.

Phone: 1-800-486-3466 Fax: 562-803-6898 Email: united@ucc-udb.com  
 Visit our *United* Website for details and complete Catalog at www.ucc-udb.com



**United California Corporation**  
**United Drill Bushing Corporation**  
**United Screw Products Company**

12200 Woodruff Ave. - Downey, CA 90241-5608  
P.O. Box 4250 - Downey, CA 90241-1250  
Ph: 562-803-1521 800-421-3466 in CA - 800-486-3466  
Fax: 562-803-6898 - 800-486-3465  
Email: united@ucc-udb.com Web: www.ucc-udb.com

## FORGED SWIVEL HOIST RINGS — SAFETY PRECAUTIONS

**MATERIAL:**  
Alloy Certified Aircraft Quality

**FINISH:**  
Phosphate per DOD-P-16232F  
(Cadmium Plated Available)

**SAFETY FACTOR:**  
5:1

**INSPECTION:**  
Magnetic Particle Inspected

**TREATMENT:**  
Certified Heat Treatment

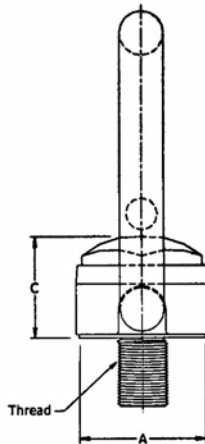
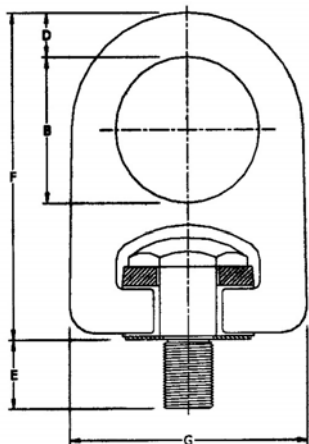

**STANDARD  
and  
METRIC  
SIZES AVAILABLE**

**Swivels 360 degrees — Pivots 180 degrees**

### STANDARD SIZES

(For METRIC SIZES, see UNITED Catalog or Website page K9.)

PART NO.	RATED LOAD	THREAD SIZE	A	B	C	D	E	F	G	TORQUE Ft / Lbs
UDB-956100	600	1/4-20	1.23	1.40	1.16	0.44	0.50	3.29	2.38	5
UDB-956102	800	5/16-18	1.23	1.40	1.16	0.44	0.50	3.29	2.38	7
UDB-956104	800	5/16-18	1.23	1.40	1.16	0.44	1.00	3.29	2.38	7
UDB-956106	1,000	3/8-16	1.23	1.40	1.16	0.44	0.50	3.29	2.38	12
UDB-956107	1,000	3/8-16	1.23	1.40	1.16	0.44	1.00	3.29	2.38	12
UDB-956008	2,500	1/2-13	2.10	2.40	1.97	0.75	0.75	5.60	4.05	28
UDB-956010	2,500	1/2-13	2.10	2.40	1.97	0.75	1.00	5.60	4.05	28
UDB-956012	2,500	1/2-13	2.10	2.40	1.97	0.75	1.25	5.60	4.05	28
UDB-956002	4,000	5/8-11	2.10	2.40	1.97	0.75	0.75	5.60	4.05	60
UDB-956004	4,000	5/8-11	2.10	2.40	1.97	0.75	1.00	5.60	4.05	60
UDB-956006	4,000	3/4-10	2.10	2.40	1.97	0.75	1.25	5.60	4.05	60
UDB-956014	5,000	3/4-10	2.10	2.40	1.97	0.75	1.00	5.60	4.05	100
UDB-956018	5,000	3/4-10	2.10	2.40	1.97	0.75	1.50	5.60	4.05	100
UDB-956204	7,000	3/4-10	2.80	3.20	2.62	1.00	1.00	7.48	5.40	100
UDB-956203	7,000	3/4-10	2.80	3.20	2.62	1.00	1.25	7.48	5.40	100
UDB-956206	7,000	3/4-10	2.80	3.20	2.62	1.00	1.50	7.48	5.40	100
UDB-956202	8,000	7/8-9	2.80	3.20	2.62	1.00	1.50	7.48	5.40	160
UDB-956205	8,000	7/8-9	2.80	3.20	2.62	1.00	1.25	7.48	5.40	160
UDB-956210	10,000	1" -8	2.80	3.20	2.62	1.00	1.25	7.48	5.40	230
UDB-956212	10,000	1" -8	2.80	3.20	2.62	1.00	1.50	7.48	5.40	230
UDB-956214	10,000	1" -8	2.80	3.20	2.62	1.00	2.25	7.48	5.40	230
UDB-956802	15,000	1-1/4-7	3.50	3.50	4.00	3.28	2.00	9.35	6.75	470
UDB-956804	15,000	1-1/4-7	3.50	3.50	4.00	3.28	2.75	9.35	6.75	470
UDB-956702	20,000	1-3/8-6	3.50	3.50	4.00	3.28	2.75	9.35	6.75	540
UDB-956404	24,000	1-1/2-6	3.50	3.50	4.00	3.28	2.75	9.35	6.75	800
UDB-956400	30,000	2" -4-1/2	3.50	3.50	4.00	3.28	3.00	9.35	6.75	800

**We repair and refurbish hoist rings. Advise us of your requirements.**

**Phone: 1-800-486-3466 Fax: 562-803-6898 Email: united@ucc-udb.com**  
**Visit our United Website for details and complete Catalog at www.ucc-udb.com**